

# 100G QSFP28 SR4

## Datasheet



### Features:

- 4 independent full-duplex channels
- Up to 25.78125Gbps data rate per channel
- MTP/MPO optical connector
- QSFP MSA compliant
- Digital diagnostic capabilities
- Capable of over 100m transmission on OM4 multi-mode fiber
- Single +3.3V power supply
- Operating case temperature: 0~70C
- Low power consumption < 3.5W
- RoHS-6 compliant

### Applications:

- IEEE802.3bm 100GBASE SR4 and 40GBASE SR4
- InfiniBand FDR and EDR

### Product Description

The TQS-X1M0-851C is a parallel 100Gbps Quad Small Form-factor Pluggable (QSFP) optical module. It provides increased port density and total system cost savings. The QSFP28 full-duplex optical module offers 4 independent transmit and receive channels, each capable of 25.78125Gbps operation for an aggregate data rate of 100Gbps over 100 meters of OM4 multi-mode fiber.

An optical fiber cable with an MPO/MTP connector can be plugged into the QSFP28 module receptacle. The module operates by a single +3.3V power supply. LVCMOS/LVTTL global control signals, such as Module Present, Reset, Interrupt and Low Power Mode, are available with the modules. A 2-wire serial interface is available to send and receive more complex control signals, and to receive digital diagnostic information.

The TQS-X1M0-851C is designed with form factor, optical/electrical connection and digital diagnostic interface according to the QSFP Multi-Source Agreement (SFF-8436). It has been designed to meet the harshest external operating conditions including temperature, humidity and EMI interference. The module offers very high functionality and feature integration, accessible via a two-wire serial interface.

## Ordering information

Part No.	Data Rate	Laser	Fiber Type	Distance* <sup>Note1</sup>	Optical Interface	Bail Color	Temp.* <sup>Note2</sup>	DDMI
<b>TQS-X1M0-851C</b>	100Gbps	850nm-VCSEL	MMF	100m	MPO	Beige	ST	Y

Note1: 100m with 50/125µm OM4 MMF

Note2: ST: -5 ~ +70 deg C

## Regulatory Compliance

Feature	Standard	Performance
Electrostatic Discharge (ESD) to the Electrical Pins	MIL-STD-883G Method 3015.7	HBM class 1, 1000volts and above, Contact discharge on Golden Finger.
Electrostatic Discharge to the enclosure	IEC-61000-4-2 GR-1089-CORE	Compliant with standards.
Electromagnetic Interference (EMI)	FCC Part 15 Class B EN55022:2006 VCCI Class B	Compliant with standards Noise frequency range: 30MHz to 18 GHz. System margins depend on customer host board and chassis design.
Immunity	IEC 61000-4-3	Compliant with standards.
Laser Eye Safety	FDA 21CFR 1040.10 and 1040.11 EN (IEC) 60825-1:2007 EN (IEC) 60825-2:2004+A1	CDRH compliant and Class I laser product.
Component Recognition	UL and CUL EN60950-1:2006	Compliant with standards.
RoHS6	2002/95/EC 4.1&4.2 2005/747/EC 5&7&13	Compliant with standards* <sup>note3</sup>

Note3:

In light of item 5 in RoHS exemption list of RoHS Directive 2002/95/EC, Item 5: Lead in glass of cathode ray tubes, electronic components and fluorescent tubes.

In light of item 13 in RoHS exemption list of RoHS Directive 2005/747/EC, Item 13: Lead and cadmium in optical and filter glass.

The three exemptions are being concerned for Telesail transceivers, because Telesail transceivers use glass, which may contain Pb, for components such as lenses, windows, isolators, and other electronic components.

## Block Diagram

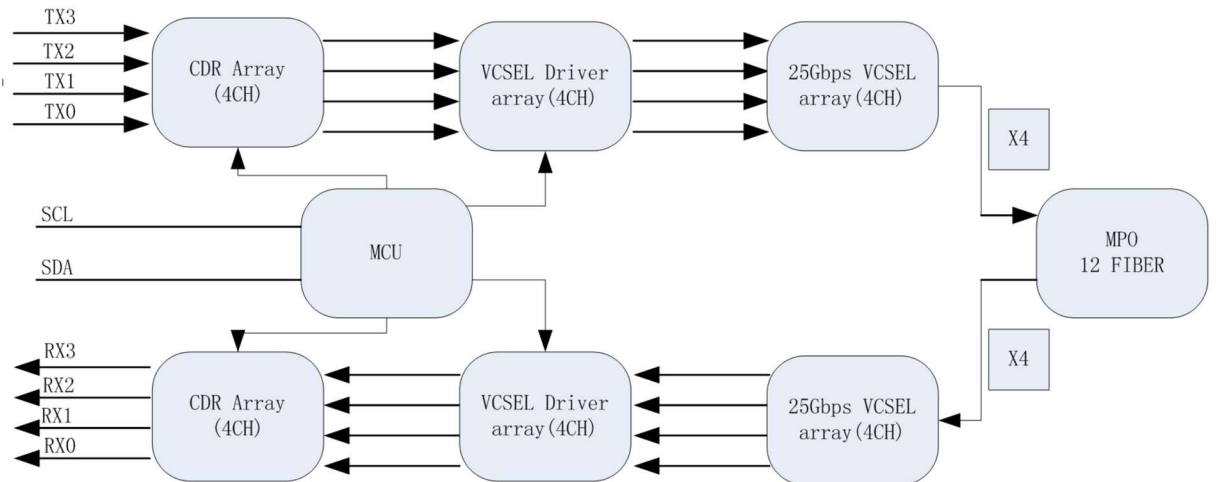

## Absolute Maximum Ratings\*<sup>Note4</sup>

Parameter	Symbol	Min	Max	Unit
Storage Temperature	Tst	-20	85	degC
Relative Humidity (non-condensation)	RH	-	85	%
Supply Voltage	VCC	-0.5	3.6	V
Voltage on LVTTTL Input	Vilvttl	-0.5	VCC+0.5	V
LVTTTL Output Current	Iolvttl	-	15	mA
Voltage on Open Collector Output	Voco	0	6	V

Note4: Exceeding any one of these values may destroy the device permanently.

## Recommended Operating Conditions

Parameter	Symbol	Min	Typical	Max	Unit	Notes
Operating Case Temperature	Topc	-5	-	70	°C	
Power Supply Voltage	VCC	3.1	-	3.5	V	
Fiber Length: 2000 MHz·km 50µm MMF (OM3)		0.5	-	70	m	
Fiber Length: 4700 MHz·km 50µm MMF (OM4)		0.5	-	100	m	

## Performance Specifications – Electrical

Parameter	Symbol	Min	Typ.	Max	Unit	Notes
Data Rate, each Lane		-	25.78125	-	Gbps	
Power Consumption (XLPP1)		-	-	3.5	W	
Supply Current	ICC	-	-	1.1	A	
Control I/O Voltage, High	VIH	2.0	-	VCC	V	
Control I/O Voltage, Low	VIL	0	-	0.8	V	
Tx Input Diff Voltage	VI	300	-	1100	mV	
Tx Input Diff Impedance	ZIN	90	100	110	Ω	

Rx Output Diff Voltage	Vo	500		800	mV
Rx Output Diff Impedance	ZOUT	90	100	110	$\Omega$

## Performance Specifications – Optical

Parameter	Symbol	Min	Typ.	Max	Unit
<b>Transmitter</b>					
Center Wavelength	$\lambda_t$	840	850	860	nm
RMS Spectral Width	Pm	-	-	0.6	nm
Average Optical Power, each Lane	Pavg	-8.4	-	+2.4	dBm
Optical Modulation Amplitude (OMA)	Poma	-6.4	-	+3	dBm
TDP, each Lane		-	-	4.3	dB
Extinction Ratio	ER	3	-	-	dB
Transmitter Eye Mask Definition		Complied with IEEE802.3bm			
Average Launch Power OFF Transmitter, each Lane	Poff	-	-	-30	dBm
<b>Receiver</b>					
Center Wavelength	$\lambda_r$	830	850	860	nm
Average Power at Receiver Input, each Lane		-10.3	-	2.4	dBm
Receiver Reflectance		-	-	-12	dB
Los Assert	LosA	-30	-	-	dBm
Los Dessert	LosD	-	-	-7.5	dBm
Los Hysteresis	LosH	0.5	-	-	dB

## Pin Descriptions

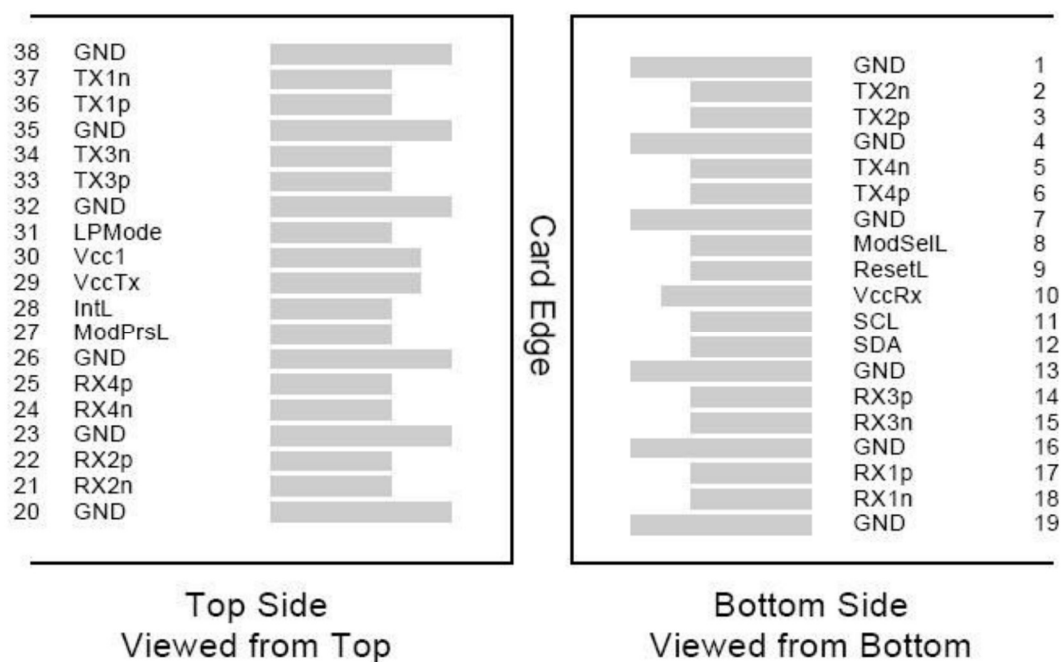

## Pin Function Definitions

PIN	Logic	Symbol	Name/Description	Note
1		GND	Ground	1
2	CML-I	Tx2n	Transmitter Inverted Data Input	
3	CML-I	Tx2p	Transmitter Non-Inverted Data output	
4		GND	Ground	1
5	CML-I	Tx4n	Transmitter Inverted Data Input	
6	CML-I	Tx4p	Transmitter Non-Inverted Data output	
7		GND	Ground	1
8	LVTTLL-I	ModSelL	Module Select	
9	LVTTLL-I	ResetL	Module Reset	
10		VccRx	+ 3.3V Power Supply Receiver	2
11	LVC MOS-I/O	SCL	2-Wire Serial Interface Clock	
12	LVC MOS-I/O	SDA	2-Wire Serial Interface Data	
13		GND	Ground	
14	CML-O	Rx3p	Receiver Non-Inverted Data Output	
15	CML-O	Rx3n	Receiver Inverted Data Output	
16		GND	Ground	1
17	CML-O	Rx1p	Receiver Non-Inverted Data Output	
18	CML-O	Rx1n	Receiver Inverted Data Output	
19		GND	Ground	1
20		GND	Ground	1
21	CML-O	Rx2n	Receiver Inverted Data Output	
22	CML-O	Rx2p	Receiver Non-Inverted Data Output	
23		GND	Ground	1
24	CML-O	Rx4n	Receiver Inverted Data Output	1
25	CML-O	Rx4p	Receiver Non-Inverted Data Output	
26		GND	Ground	1
27	LVTTTL-O	ModPrsL	Module Present	
28	LVTTTL-O	IntL	Interrupt	
29		VccTx	+3.3 V Power Supply transmitter	2
30		Vcc1	+3.3 V Power Supply	2
31	LVTTTL-I	LPMode	Low Power Mode	
32		GND	Ground	1
33	CML-I	Tx3p	Transmitter Non-Inverted Data Input	
34	CML-I	Tx3n	Transmitter Inverted Data Output	
35		GND	Ground	1
36	CML-I	Tx1p	Transmitter Non-Inverted Data Input	
37	CML-I	Tx1n	Transmitter Inverted Data Output	
38		GND	Ground	1

Note1. GND is the symbol for signal and supply (power) common for QSFP modules. All are common within the QSFP module and all module voltages are referenced to this potential unless otherwise noted. Connect these directly to the host board signal common ground plane.

Note2. VccRx, Vcc1 and VccTx are the receiver and transmitter power suppliers and shall be applied concurrently.

Recommended host board power supply filtering is shown below. Vcc Rx, Vcc1 and Vcc Tx may be internally connected within

the QSFP transceiver module in any combination. The connector pins are each rated for a maximum current of 500mA.

## Optical Interface Lanes and Assignment

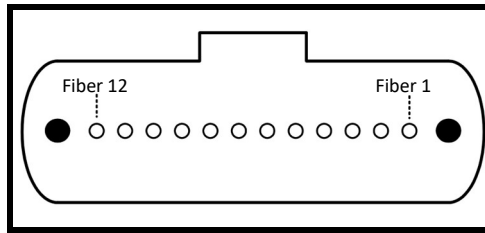

Fiber #	Lane Assignment
1	RX0
2	RX1
3	RX2
4	RX3
5	Not used
6	Not used
7	Not used
8	Not used
9	TX3
10	TX2
11	TX1
12	TX0

## Application Reference Diagram

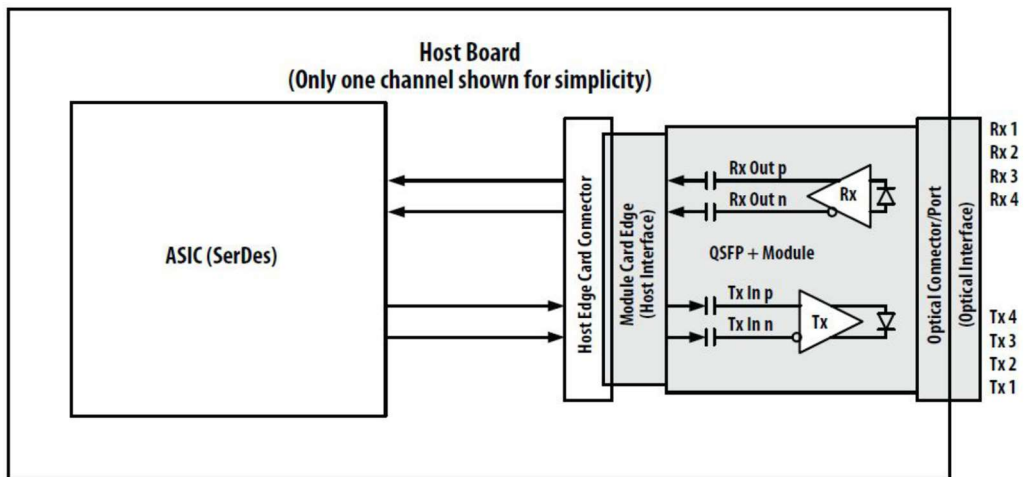

## Recommended Host Board Power Supply Circuit

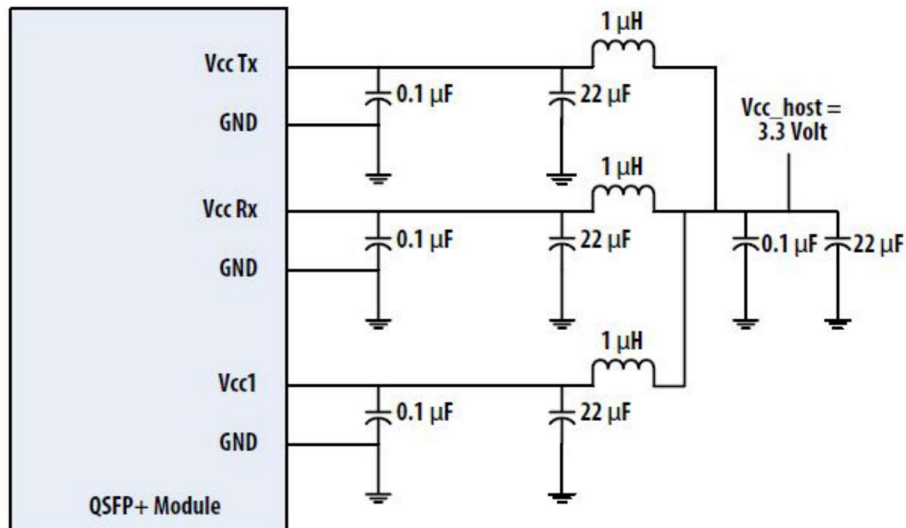

## Mechanical Dimension

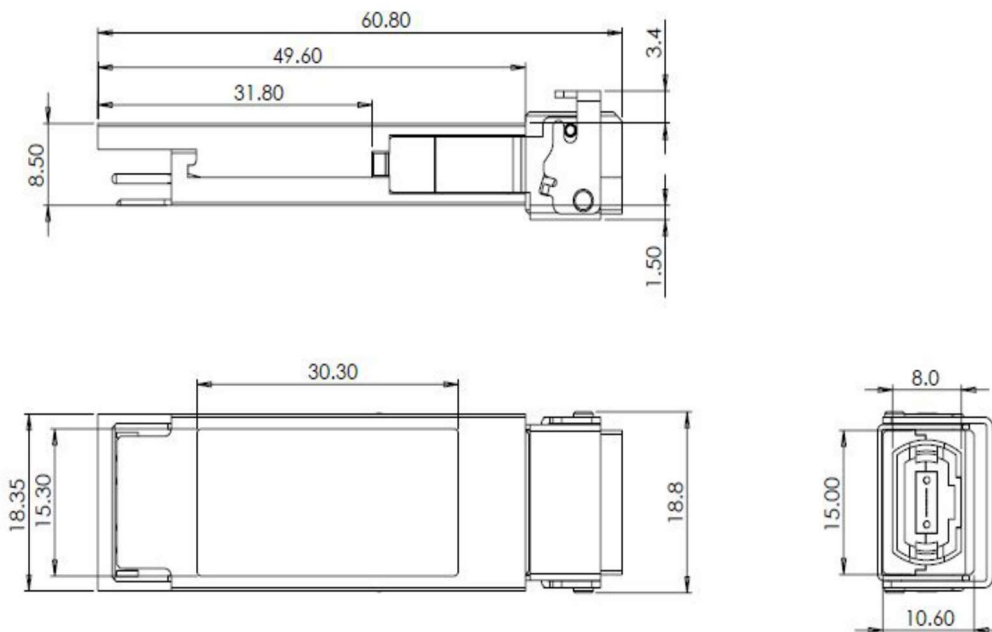

## Eye Safety

These transceivers are Class 1 laser products. It complies with IEC-60825 and FDA 21 CFR 1040.10 and 1040.11. The transceiver must be operated within the specified temperature and voltage limits. The optical ports of the module shall be terminated with an optical connector or with a dust plug.

## Obtaining Document

You can visit our website: <http://www.telesail.com>

Or contact Telesail Technology Inc. listed at the end of the documentation to get the latest document.

## Notice

Telesail reserves the right to make changes to or discontinue any optical link product or service identified in this publication, without notice, in order to improve design and/or performance.

Applications that are described herein for any of the optical link products are for illustrative purposes only. Telesail makes no representation or warranty that such applications will be suitable for the specified use without further testing or modification.

**Add: #No.3 Sichuan Str.,Shiyan 442024,Hubei Province. P.R. CHINA**

**Tel: (+86) 18588427281/Fax: (+86) 0719-8511538**

**E-mail: sale@telesail.com**

**<http://www.telesail.com>**

**© Copyright Telesail 2014 All rights reserved.**